



LUMENDi

DiLumen C¹

Endolumenal Interventional Platform

INSTRUCTIONS FOR USE

Obsolete Revision



LUMENDi

253 Post Road West

Westport, CT, 06880 • USA

info@lumendi.com • www.lumendi.com

1-844-481-0822

265-06359 REVISION C
2023-02

THIS PAGE INTENTIONALLY LEFT BLANK

Obsolete Revision

INTENDED USE

The DiLumen C¹™ Endolumenal Interventional Platform (“DiLumen C¹” or “the device”) is an endoscope accessory intended to ensure complete positioning of an endoscope in the large intestine, and assist with optical visualization, diagnosis, and endoscopic treatment.

SAFETY AND PRECAUTIONS

- Read and understand this manual before operating the device and save this manual for future reference.
- Failure to read and thoroughly understand the information presented in this manual may result in injury to the patient and/or user. In addition, failure to follow the instructions in this manual may result in damage to and/or malfunction of the device.
- Consult the medical literature relative to complications, hazards, and techniques prior to the performance of any endoscopic procedure.
- DiLumen C¹ should only be used by a physician trained in flexible endoscopy. A thorough understanding of the procedure, clinical applications, and risks associated with flexible endoscopy is required before using the device in a procedure.
- It is the responsibility of every operator to ensure they have been properly trained prior to conducting any procedure using DiLumen C¹.
- To ensure that the DiLumen C¹ can reach the target location, make sure the appropriate length device is used. Options include 130 cm and 103 cm.
- Ensure that the outer diameter (“OD”) of the endoscope is compatible with the inner diameter (“ID”) of DiLumen C¹. The device is intended to be used only with endoscopes with outer diameters ranging from 8.9mm to 11.8mm in size.
- Do not use the device if the package is open, damaged, or expired. Use of a non-sealed or expired package might lead to adverse health consequences.
- DiLumen C¹, including the Inflation System, is a single-use device and was not designed to be reprocessed or re-used. LUMENDI cannot verify that reprocessing can clean or maintain the structural integrity of the device to ensure patient and/or user safety. Reprocessing or re-using the device may lead to device failure and/or contamination and/or cross-infection, which may result in adverse health consequences.
- It is recommended to examine the patient’s large intestine with an endoscope alone prior to installing the DiLumen C¹ to determine if the anatomy presents any listed Warning, Precaution, Contraindication, or potential surgical challenges. Prior abdominal-pelvic surgery (i.e. hysterectomy, GU or colonic surgery), tortuous/floppy colon and hernias may make using the DiLumen C¹ more challenging.
- The balloon at the end of the disposable device can be punctured or damaged. Handle with care and avoid exposing to sharp objects or excessive manipulation.
- All warnings, precautions, and contraindications relevant to the endoscope are applicable to the use of the endoscope with the device. For any information required for the use of the endoscope, please refer to the corresponding instructions for use.
- Do not use this device for any purpose other than its intended use.

COMPLICATIONS

Possible complications that may result from the use of DiLumen C¹ include those relevant to standard endoscopy and other similar procedures. Possible complications include, but may not be limited to perforation, hemorrhage, infection, or intestinal blockage.

CONTRAINDICATIONS

Contraindications include, but are not limited to, those specific to any endoscopic procedure, use of an overtube, or any endoscopic procedure performed in conjunction with an overtube, including:

- Resistance in overtube advancement
- Colonic narrowing associated with but not limited to radiation injury, tumor, or inflammatory condition
- Angulated sigmoid colon
- Recent surgical alteration and/or anastomoses or rectal reconstruction
- Intractable patient discomfort
- Inability to straighten the sigmoid colon

Obsolete Revision

Table of Contents

I.	INTRODUCTION	6
1.	Purpose	6
2.	Definitions and Glossary	6
3.	Specifications.....	6
II.	DEVICE DESCRIPTION	7
III.	PREPARATION BEFORE THE PROCEDURE	9
IV.	PERFORMING THE PROCEDURE	11
V.	FINALIZING THE PROCEDURE	13
VI.	DISPOSAL OF THE SINGLE-USE DILUMEN C ¹ DEVICE.....	13
VII.	TROUBLESHOOTING.....	13
1.	Balloon cannot be deflated.....	13
VIII.	STORAGE	14
IX.	SYMBOL LEGEND.....	15

Obsolete Revision

I. INTRODUCTION

1. Purpose

LUMENDI provides medical devices for endolumenal gastrointestinal procedures. This Instruction For Use (IFU) manual describes how to operate the DiLumen C¹ device safely and effectively during a procedure within the large intestine. Before use, thoroughly review this manual. Keep this manual in a safe, accessible location.

2. Definitions and Glossary

Tool Mount: An accessory to DiLumen C¹ intended to be used in conjunction with a DiLumen C¹ for holding the Flange during surgical procedures. It is a reusable multi-positional stabilization apparatus.

Inflation System: Comprised of the inflation handle, one balloon, inflation line and its connector, which are part of the Sleeve Assembly.

3. Specifications

- Storage environment: 0-40° C; Relative humidity: 15-85%
- Balloons:
 - Outer diameter: 60 mm inflated
 - Nominal pressure: 45 mmHg
 - Pressure range: 33 – 55 mmHg
- Compatible endoscope tip diameter: 8.9 mm - 11.5 mm

- Product REF number:

REF (qty per box)	Endoscope Working Length
I-210 (-1,-5)	130 cm
D-2101 (-1,-5)	103 cm

- To be used with DiLumen Tool Mount.
- DiLumen C¹ is a non-sterile device that does not require cleaning or sterilization prior to use.

Obsolete Revision

II. DEVICE DESCRIPTION

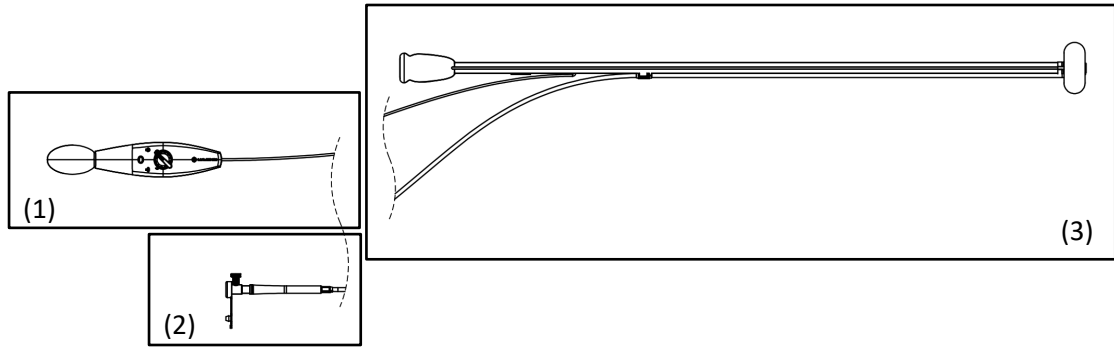

The DiLumen C¹ device includes the following components:

- (1) Inflation Handle
- (2) External Tool Channel and Flange
- (3) Sleeve Assembly

1. Sleeve Assembly

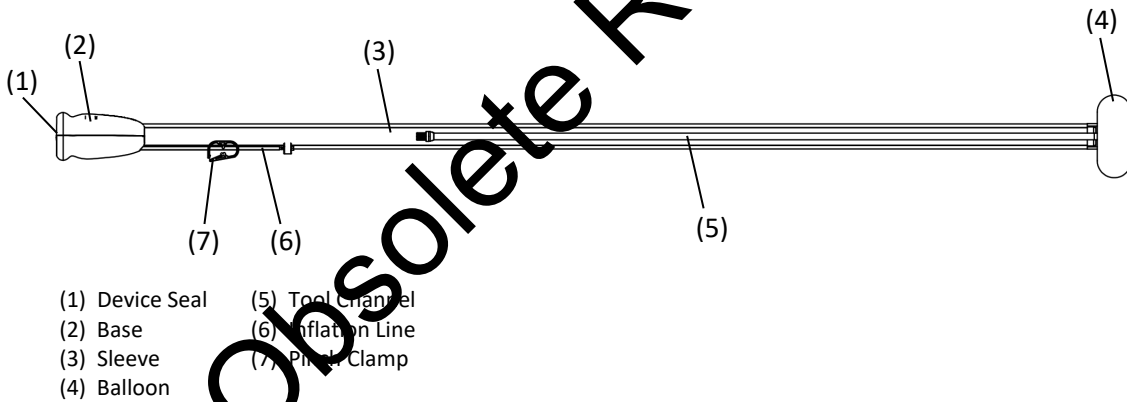

- (1) Device Seal
- (2) Base
- (3) Sleeve
- (4) Balloon
- (5) Tool Channel
- (6) Inflation Line
- (7) Pinch Clamp

The Sleeve supports a Balloon and an external Tool Channel, and is fixed onto the endoscope through the Device Seal at the rear of the base.

2. Inflation Handle System

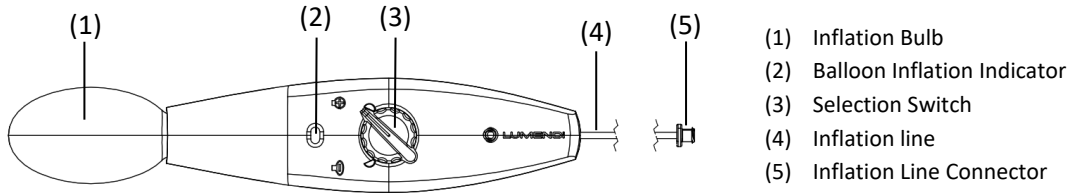

The Inflation Handle enables manual inflation or deflation of the balloon by squeezing the Inflation Bulb. The Inflation Handle is connected to the Sleeve via the Inflation Line and Connector. The Selection Switch enables selection of either inflation or deflation mode. The Inflation Indicator provides information on the inflation status of the balloon:

- Partially Red: Deflated
- Mostly Yellow: Partially inflated / deflated
- Only Green: Fully inflated

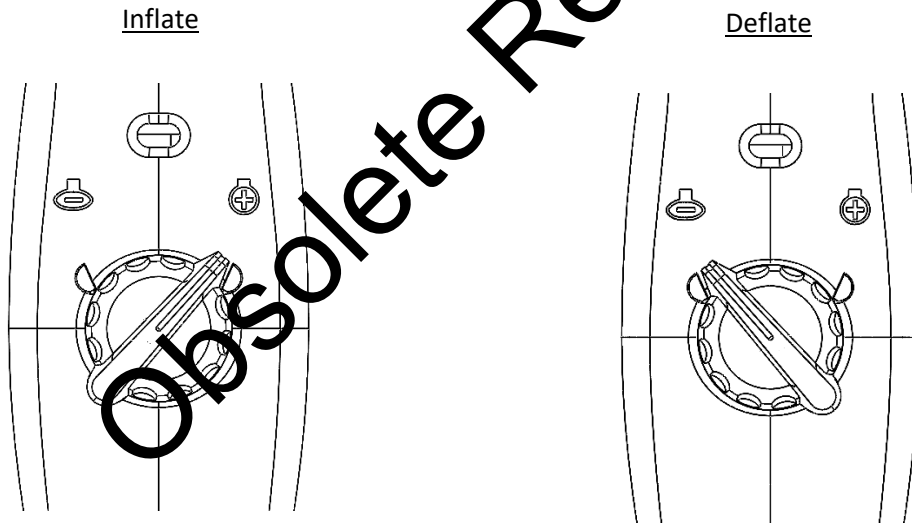

NOTE

During the transition from a deflated to inflated state or an inflated to deflated state, the yellow color is visible, and the indicator may oscillate before reaching a steady state.

3. External Tool channels

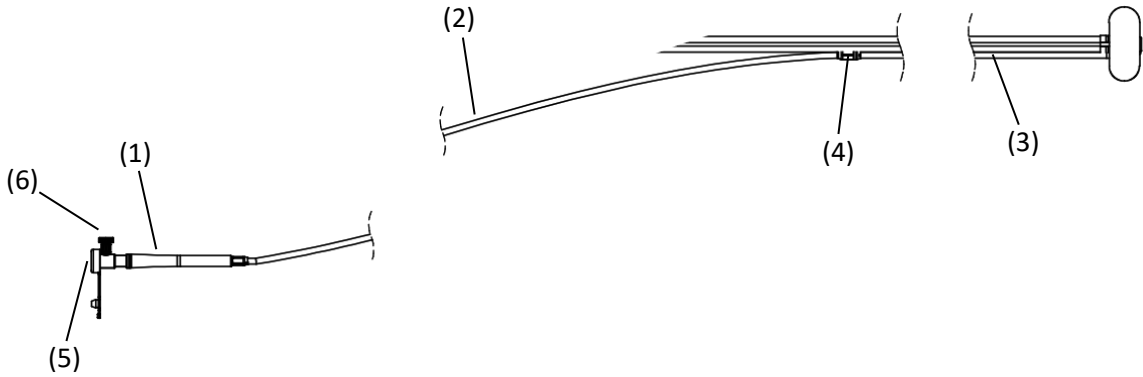

- | | | |
|----------------------------|----------------------------|---------------------|
| (1) Flange | (3) Tool Channel | (5) Seal |
| (2) Tool Channel Extension | (4) Tool Channel Connector | (6) Instrument Lock |

The Tool Channel is attached to the distal Sleeve at the tip. The Tool Channel is connected to the Tool Channel Extension via the Tool Channel Connector. Instruments are inserted into the Flange, which can be attached either to the Tool Channel or the Extension.

III. PREPARATION BEFORE THE PROCEDURE

The DiLumen C¹ device is a single use device that is supplied in a sealed tray. Before use, the device and packaging should be inspected to ensure no damage has occurred. If any damage is noted, **DO NOT USE**.

CAUTION

Obsolete Revision

Do not use DiLumen C¹ if the package is open, damaged, or expired. The use of a device from a compromised package may result in patient injury, illness, or damaged structural integrity of the device.

To avoid soiling or damaging the device, use caution when removing the device from its packaging, not allowing the device to come in contact with unclean surfaces.

Connect the Inflation Line securely to ensure proper inflation and deflation of the Balloon.

Verify that nothing is crushing, bending, or twisting the Inflation Line to ensure proper inflation and deflation of the Balloon.

1. Remove the Sleeve Assembly and Inflation Handle from the tray and uncoil the Sleeve and the Inflation Line. Lay the Sleeve Assembly straight and flat.
2. Lubricate the Sleeve. The inside of the DiLumen C¹ incorporates a self-lubricating coating. The coating activates by hydrating with water or saline. The coating reduces friction between the endoscope and the sleeve lumen. To activate the coating execute the following:

Required materials:

- 30cc Luer-Lock™ dispensing syringe
- Sterile water or saline

Lubricating instructions:

- Fill the syringe with sterile water (min 30 cc).
- Hold the distal and proximal sleeve ends so the sleeve forms the shape of a U.
- Inject a minimum of 30cc of water or saline into the sleeve through the device handle.
- Move the distal and proximal sleeve ends up and down so the liquid contacts the sleeve's entire internal surface. Continue this hydrating process for a minimum of 30 seconds.
- After 30 seconds, discard the excess liquid through the distal end of the device.

3. After the Sleeve is lubricated, insert a clean endoscope through the Device Seal at the back of the Base and into the Sleeve. Advance the endoscope through the Sleeve until the distal end of the device is flush with the distal end of the endoscope.

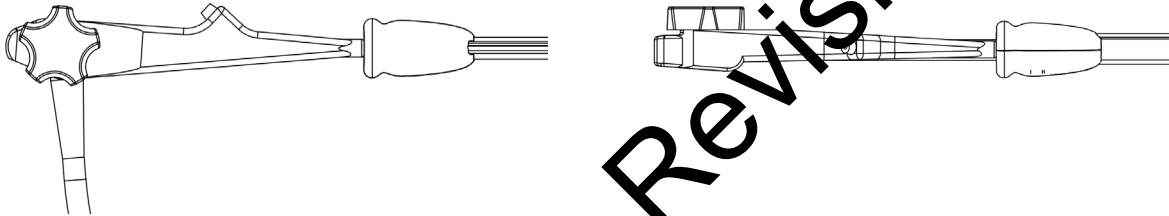

4. Connect the Inflation Line from the Inflation Handle to the Sleeve Assembly using the Inflation Line Connector at the end of the line.
5. Fully inflate and deflate the balloon once to ensure/confirm that the inflation system is working properly.
6. Apply a water-based lubricant around the circumference of the distal end of the Sleeve. The endoscope bending section should extend in front of the Balloon to facilitate navigation in the large intestine. Lubricate the Sleeve avoiding excessive lubrication on the Balloon.
7. Attach the Tool Channel Extension to the Tool Channel using the Tool Channel Connector at the end of the Tool Channel. The extension should be matched according to the shape of the connector.
8. Attach the Flange to the Tool Channel Extension and insert the plug into the Seal.
9. DiLumen C¹ is now ready for use.

IV. PERFORMING THE PROCEDURE

CAUTION

DiLumen C¹ should only be used by a physician trained in flexible endoscopy. A thorough understanding of the procedure, clinical applications and risks associated with flexible endoscopy is required before using the device in a procedure.

NOTE

If targeting multiple locations within the intestine, the most proximal location should be targeted first, followed by the second most proximal location, etc.

A – Navigation to target location

1. Verify that the Balloon is fully deflated.
2. Apply lubricant to the tip of the Dilumen C¹.
3. Insert the endoscope with the mounted device (Balloon deflated) into the large intestine and navigate as performed in standard colonoscopy until the target location is reached.

NOTE

Liberal use of insufflation and water irrigation is helpful when navigating the DiLumen C¹.

B – Deployment of Balloon

4. Orient the endoscope with DiLumen C¹ so that the target lesion is positioned as desired on the monitor view; for instance, down in the 6:00 position.

5. Inflate Balloon to stabilize the endoscope by turning the Selection Switch to the inflate (+) position and squeezing the Inflation Bulb slowly until the Inflation Indicator is stable and shows green only. The Pinch Clamp may be closed at this time if desired.

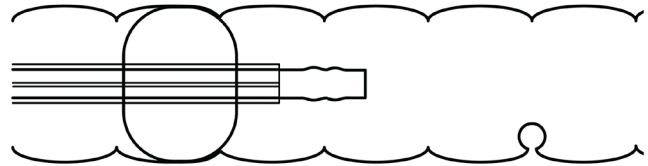

NOTE

Squeezing the Inflation Bulb slowly is more effective for inflating and deflating the balloons.

6. Verify proper anchoring by gently tugging on the endoscope and device and visually assessing the grip of the colon through the endoscopic view.

7. The platform is now ready. Secure the Flange into the tool support and adjust the tool support for optimal configuration. Insert the plugs into the Seal if no tool is inserted into the Tool Channel to prevent any back leak.

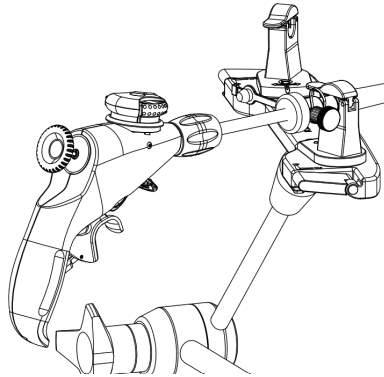

8. The procedure can now be performed. Insufflate the colon until acceptable endoscopic visualization is achieved.

9. At any point during the procedure, the instrument lock can be turned clockwise to lock the instrument into place. Turn the lock counterclockwise to release.

CAUTION

As in standard endoscopy, a minimum amount of gas insufflation should be used to maintain an acceptable field of view inside the intestine. An excess of insufflation might result in over-inflation and injury to the patient.

To avoid patient injury, always view an instrument when it is exiting the External Tool Channel. Do not advance tools out of the External Tool Channel unless the distal end of the tool channel is in the endoscope view.

If excessive resistance to the advancement of a tool inside the External Tool Channel is felt, the tool should not be advanced further. The tool should be retracted, and the endoscope reoriented and straightened, as much as possible, before inserting the tool again.

Do not attempt to retroflex an endoscope while docked inside the Sleeve.

C. Deflation of the Balloon

10. Once the endoluminal procedure is complete, remove any tool from the Tool Channels and insert the plugs into the Seals to avoid back flow.

CAUTION

Do not attempt to move the endoscope and the DiLumen C¹ device without fully opening the Pinch Clamp and deflating the balloon.

11. Deflate the Balloon by opening the Pinch Clamp, if it was closed. Turning the Selection Switch to the *deflate setting* and squeeze the Inflation Bulb slowly until the Inflation Indicator is showing mostly red for full deflation.

12. If needed, navigate the endoscope and device to the next target location and repeat these steps.

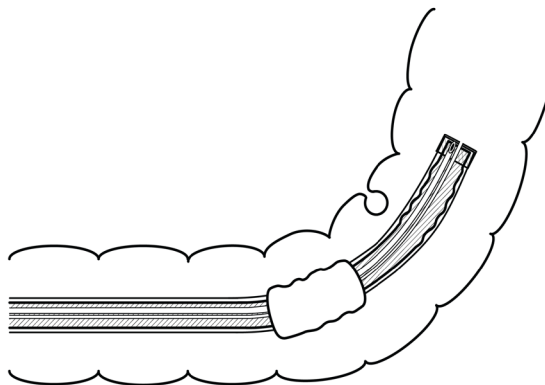

V. FINALIZING THE PROCEDURE

1. Remove the Flange from the Tool Support.

2. Verify that the balloon is deflated and carefully remove the endoscope and device from the patient.

NOTE	If during withdrawal of the endoscope the intestine wall needs to be examined or if an intervention is needed (e.g., biopsy, polypectomy, etc.), the Balloon may be deployed again to stabilize the endoscope and facilitate the procedure. Deflate the Balloon before further withdrawal of the endoscope.
-------------	---

3. Straighten the endoscope's tip and pull the endoscope out of the Sleeve Assembly completely.

CAUTION	Additional tools are not necessary to assist in loosening and/or removal of the device. Use of additional tools to facilitate removal may result in damage to the endoscope. During the procedure, fluids might build up between the endoscope and the Sleeve. Carefully remove the endoscope from the Sleeve Assembly to avoid fluid spillage.
----------------	--

VI. DISPOSAL OF THE SINGLE-USE DILUMEN C¹ DEVICE

After use, the DiLumen C¹ single-use device is contaminated. Handle and dispose of the device, and all of its components, in accordance with accepted medical practice and applicable local, state, and federal laws and regulations.

CAUTION	Do not re-use the single-use DiLumen C ¹ device.
----------------	---

VII. TROUBLESHOOTING

1. Balloon cannot be deflated

1. Check that the Pinch Clamp on the Inflation Line is not closed.

2. Check if the Inflation Line between the Base and the Inflation Handle is bent or kinked, and if the Inflation Line Connector is properly connected. Attempt to deflate by turning the Selection Switch to the *deflate (-)* position and squeeze the Inflation Bulb slowly until the Inflation Indicator is showing mostly red for full deflation.

3. If the Balloon still does not deflate, de-couple the connector and allow the Balloon to deflate. Carefully move the device to ensure the Balloon has deflated.

4. If the Balloon still does not deflate, carefully pass a small diameter endoscope alongside the existing endoscope and device. Once visualization of the Balloon is achieved, use an endoscopic tool to puncture the Balloon and allow deflation. Assess Balloon deflation through the endoscopic view of the small diameter endoscope.

5. Remove the small diameter endoscope. With balloon deflated and any endoscopic tools removed from the endoscope, carefully remove the endoscope and the device from the patient's body.

VIII. STORAGE







The DiLumen C¹ device should be stored at room temperature under dry conditions.







CAUTION

Do not use device after use by date printed on label.

Obsolete Revision

IX. SYMBOL LEGEND

	Quantity Symbol
	Federal (US) law restricts this device to sale by or on the order of a physician
	Consult Instructions For Use
	Use by date
	Catalog Number
	Lot Number
	Humidity Limitation

	Do not use if package is damaged or open
	Do not re-use
	Temperature limitation
	Keep dry
	Manufacturer
	Caution
	Non-sterile

Obsolete Revision

THIS PAGE INTENTIONALLY LEFT BLANK

Obsolete Revision